

Portico 5017

Mobile DI / Pre / Compressor

By:



Serial #:



Operations Manual

Portico 5017: Mobile DI / Pre / Compressor User Guide

Thank you for your purchase of the 5017 Mobile DI / Pre / Compressor. Everyone at Rupert Neve Designs hope you enjoy using this tool as much as we have enjoyed designing and building it. Please take note of the following list of safety concerns and power requirements before the use of this or any Portico Series product.

Safety

It's usual to provide a list of "do's and don'ts" under this heading but mostly these amount to common sense issues. However here are some reminders:

The Portico 5017 dissipates about 7 watts, which means that it will get warm in use. The heat generated is radiated through the case work. To avoid overheating Portico™ modules should not be stacked immediately above or adjacent to other equipment that gets hot. Also bear in mind that other equipment may radiate strong hum fields which could spoil the performance of your Portico module.

Don't operate your Portico™ module in or around water! Electronic equipment and liquids are not good friends. If any liquid is spilled such as soda, coffee, alcoholic or other drink, the sugars and acids will have a very detrimental effect. Sugar crystals act like little rectifiers and can produce noise (crackles, etc.). SWITCH OFF IMMEDIATELY because once current starts to flow, the mixture hardens, can get very hot (burnt toffee!) and cause permanent and costly damage. Please contact support as soon as possible at support@rupertneve.com for resolution.

Don't be tempted to operate a Portico module with the cover removed. The cover provides magnetic screening from hum and R.F. stray fields.

Power Requirements

Each Portico 5017 module has a high quality DC to DC converter that provides carefully stabilized and filtered +/- 17.5 VDC for the amplifiers. The meticulous audio quality of your Portico is protected by the internal converter and does not depend primarily on the external mains power supply. The input is protected from reverse polarity. The connector center pin must be positive. The converters will work from any DC supply from 9 to 18 volts that is reasonably "clean". The power supply normally provided with the 5017 is a high quality, robust, and very reliable switched mode power supply. There are no special requirements for the Portico low voltage units other than that they must be of good quality, reliable, and able to supply enough current for the number of modules in use.

The great advantage of this system is that there are no common D.C. supply rails that are directly shared by other modules.

In a traditional console, large, bi-polar regulated supplies were used, necessarily having a shared common 0 "ground" wire. Crosstalk between modules resulted, often accompanied by R.F. interference due to the unbalanced loop "antennas" that were inevitably present. This interference, in some cases, could actually be heard, but even at low levels below audibility there was a potential intermodulation with the desired signal. Of course this represented both a quantitative and subjective intrusion affecting sound quality.

One of the advantages of the Portico method of feeding equipment is that external power units will work from almost any of the very wide range of mains supply voltages and frequencies that are found world-

wide. While many different types of mains power wall sockets are found in different countries, Portico 5017 module power units leave the factory with standard US plugs. If required, any suitable connecting cord may be substituted. Avoid using a mains power outlet that is on the same circuit as air conditioning of other equipment that regularly switches on and off. Unplug your Portico power units during a thunder storm or if it will be unused for a long period.

Portico modules can alternatively be powered from a 12 volt battery, in which case the supplied AC power unit is not needed. When using a 12 volt battery, choose one that has enough capacity to power your Portico 5017 - or your complete assembly of Portico modules - for the expected duration of your session.

Portico 5017: Block Diagram

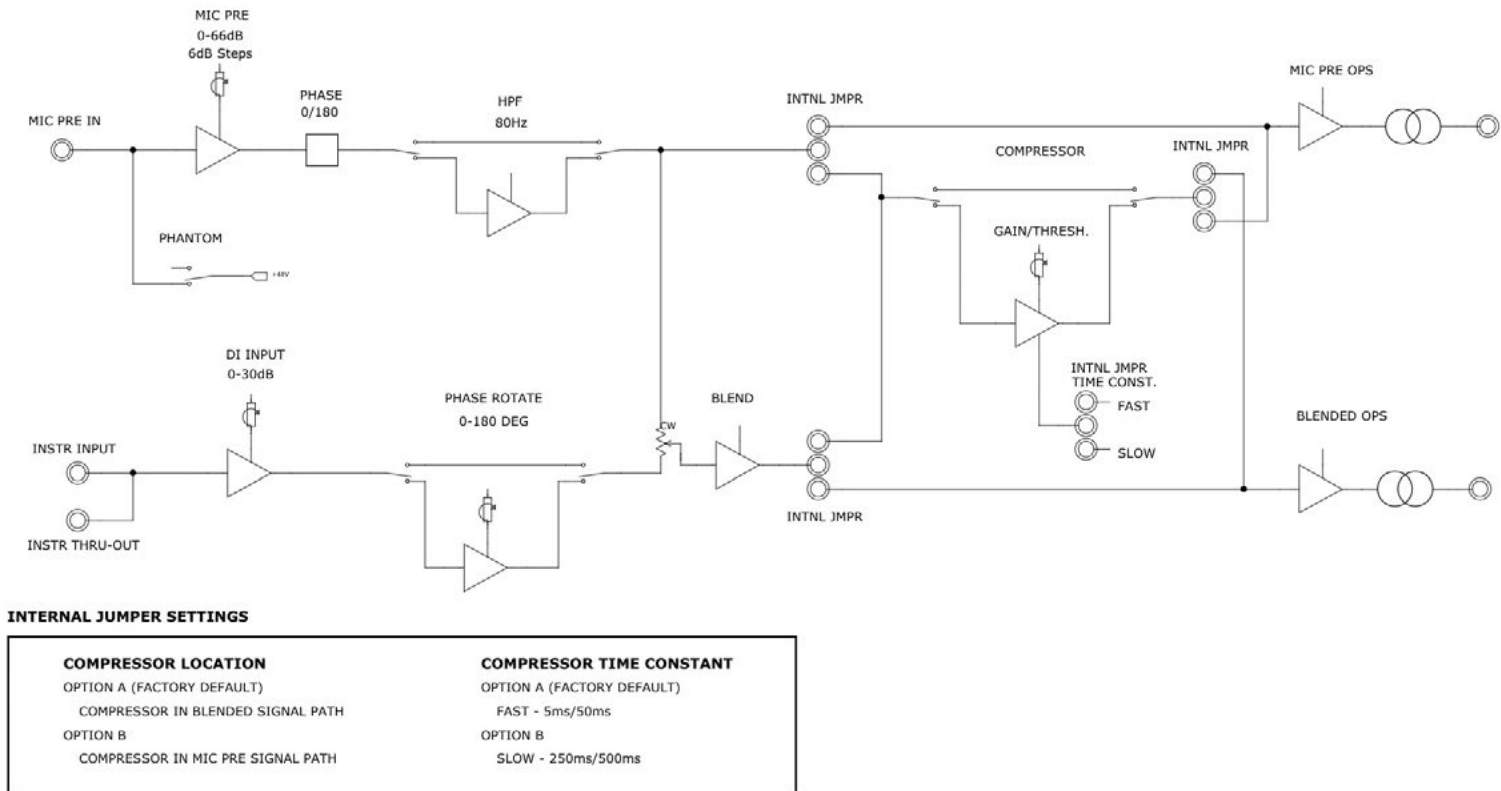

Portico 5017: Front Panel

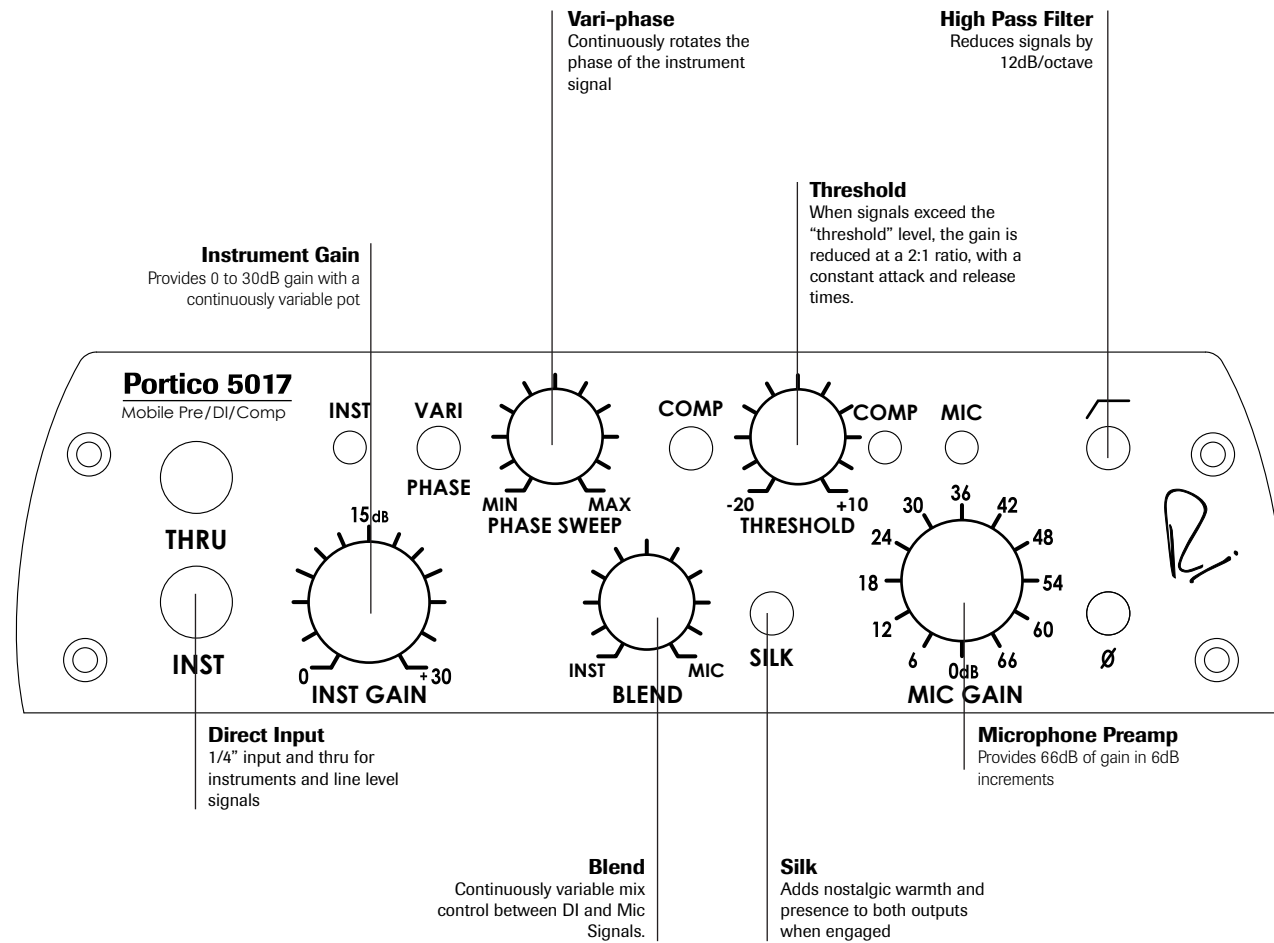

Portico 5017: Back Panel

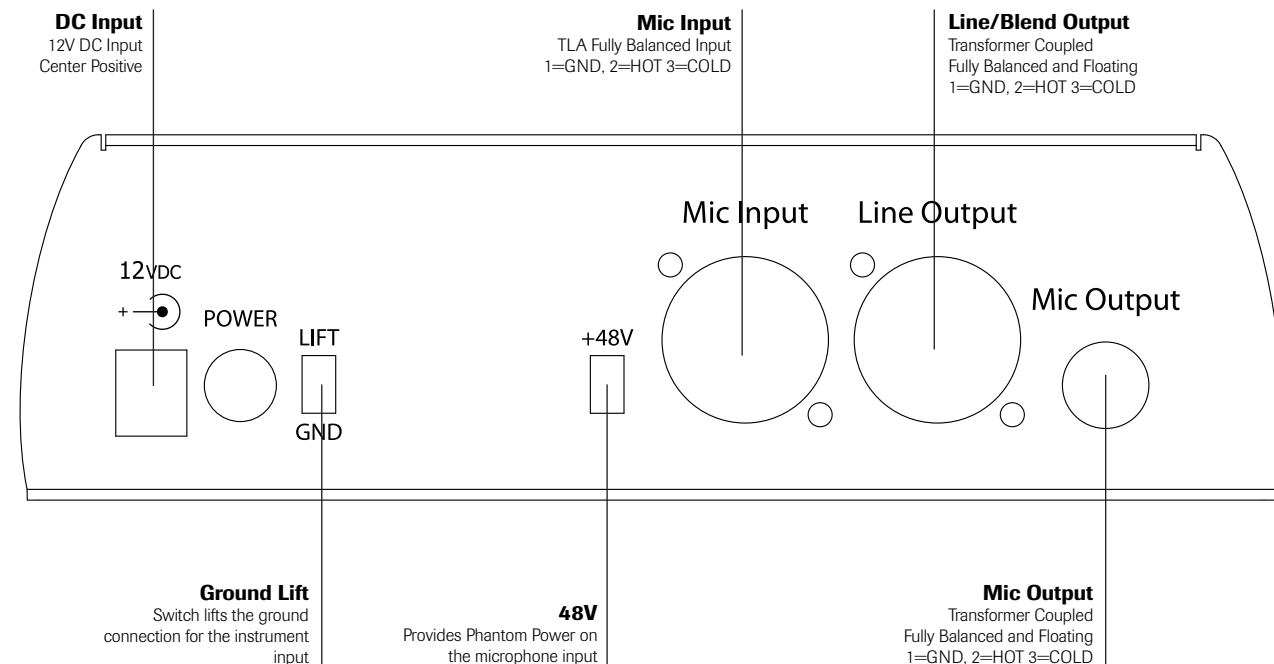

MICROPHONE PREAMPLIFIER DESIGN NOTES

In former years, before the introduction of solid state amplifiers, transformers were necessary to step up to the very high input impedance of tubes, and to provide a balanced input for the microphone line. An input impedance of 1,000 or 1,200 ohms became established for microphones having a source impedance of 150 or 200 ohms, with connection being made on a twisted twin screened cable (This type of cable, while excellent for low impedance work, has high capacitance between its conductors and between each conductor and screen. Resultant high frequency losses are excessive with piezo pickups and may cause resonances with magnetic pickups.) Thus microphones were not heavily loaded. Condenser microphones worked off high voltage supplies (300V!) on the studio floor which polarized the diaphragms and powered a built-in pre-amplifier. More and more microphones were needed as "Pop" music gained ground and this led to the popular and efficient method of 48-volt "Phantom" powering that was built into the multi-channel recording Console – in place of numerous bulky supplies littering the studio, a miniature pre-amplifier now being fitted inside the microphone casing.

The 48-volt supply was fed to the microphone through balancing resistors so it was impossible for this voltage to actually reach the microphone, resulting in low polarizing volts and virtual starvation of the little pre-amp inside the microphone. Nevertheless amazingly good microphones were designed and made, becoming the familiar product we use today. If a low value resistive load is connected to the output of an amplifier, that amplifier has to produce power in order to maintain a voltage across that load. Obviously if we want more voltage (output from the microphone) we need to provide a larger supply for the amplifier or settle for a lighter load. A microphone is a voltage generator, not a power amplifier. Most microphones give their most accurate performance when they are not loaded by the input impedance of a traditional preamplifier. If the microphone uses an electronic circuit (transformerless) output, a low value of load impedance can possibly stress the little microphone pre-amplifier, causing slew rate and compression at high levels.

On the other hand, a high value of load impedance allows the microphone to "breathe" and give of its best, this being particularly advantageous with very high level percussive sounds. If the microphone has an inductive source (such as would be the case if it has a transformer output) a low value of load impedance causes the high frequencies to roll off due to leakage inductance in the transformer in addition to the above amplifier distortion (This can be an advantage with some microphones!).

For this reason we have provided a high value of input impedance that will load microphones to the smallest possible extent and makes the best possible use of that limited "Phantom" 48-volts supply.

DYNAMIC RANGE

Traditionally, high quality microphones such as ribbons, had very low source impedances – as low as 30 ohms at the output of a ribbon matching transformer. Moving coil microphones were higher but had not been standardized as they are today. Condenser microphones, before the days of semiconductors, used tube head amplifiers that were coupled to the outgoing line with a transformer. Microphone amplifiers, such as in a mixing console, also used tubes and these typically have a high input impedance.

Microphones are Voltage generators, not Power generators. It is always desirable to deliver the maximum possible signal voltage into the amplifier. It was traditional to provide an amplifier input impedance of about 1,000 or 1,200 ohms; about 5 or 6 times the source impedance of the microphone. This provided relatively low loading on the microphone – whatever its type – and went a long way to avoid voltage loss.

In the early 1960's when the "Pop" music scene was exploding and sound levels in the Studio became very high, there was concern that the head amplifiers in Condenser microphones would overload if the Console input impedance was too low. In the early days of Consoles I was asked to provide higher input impedance than the normal 1,000 ohms. This of course, resulted in less "step-up" in the Console input transformer and there were then fears that we would lose out at the other end of the scale; Noise. The fact that microphones were less heavily loaded allowed an increased microphone signal. The reduced loading also resulted in less deviation of frequency response due to variation of microphone impedance and consequently less distortion at high levels.

The Portico 5017 microphone amplifier provides an input impedance of 10,000 ohms which means that variations in microphone source impedance with frequency, have only a very small effect on the sonic quality. This high input impedance has minimal effect on microphone output and loading with the result that microphone distortion is very low adding up to a noticeable improvement in "transparency".

A NOTE ON DISTORTION

The human hearing system is a remarkably complex mechanism and we seem to be learning more details about its workings all the time. For example, Oohashi demonstrated that arbitrarily filtering out ultrasonic information that is generally considered above our hearing range had a measurable effect on listener's electroencephalo-grams. Kunchur describes several demonstrations that have shown that our hearing is capable of approximately twice the timing resolution than a limit of 20 kHz might imply ($F=1/T$ or $T=1/F$). His peer reviewed papers demonstrated that we can hear timing resolution at approximately with 5 microsecond resolution (20 kHz implies a 9 microsecond temporal resolution, while a CD at 44.1k sample rate has a best-case temporal resolution of 23 microseconds).

It is also well understood that we can perceive steady tones even when buried under 20 to 30 dB of noise. And we know that most gain stages exhibit rising distortion at higher frequencies, including more IM distortion. One common IM test is to mix 19 kHz and 20 kHz sine waves, send them through a device and then measure how much 1 kHz is generated ($20-19=1$). All this hints at the importance of maintaining a sufficient bandwidth with minimal phase shift, while at the same time minimizing high frequency artifacts and distortions. All of the above and our experience listening and designing suggest that there are many subtle aspects to hearing that are beyond the realm of simple traditional measurement characterizations.

The way in which an analog amplifier handles very small signals is as important as the way it behaves at high levels. For low distortion, an analog amplifier must have a linear transfer characteristic, in other words, the output signal must be an exact replica of the input signal, differing only in magnitude. The magnitude can be controlled by a gain control or fader (consisting of a high quality variable resistor that, by definition, has a linear transfer characteristic.) A dynamics controller - i.e. a compressor, limiter or expander - is a gain control that can adjust gain of the amplifier very rapidly in response to the fluctuating audio signal, ideally without introducing significant distortion, i.e. it must have a linear transfer characteristic. But, by definition, rapidly changing gain means that a signal "starting out" to be linear and, therefore without distortion, gets changed on the way to produce a different amplitude.

Inevitably our data bank of "natural" sound is built up on the basis of our personal experience and this must surely emphasize the importance of listening to "natural" sound, and high quality musical instruments within acoustic environments that is subjectively pleasing so as to develop keen awareness that will contribute to a reliable data bank. Humans who have not experienced enough "natural"

sound may well have a flawed data bank! Quality recording equipment should be capable of retaining "natural" sound and this is indeed the traditional measuring stick. And "creative" musical equipment should provide the tools to manipulate the sound to enhance the emotional appeal of the music without destroying it. Memory and knowledge of real acoustic and musical events may be the biggest tool and advantage any recording engineer may possess.

One needs to be very careful when one hears traces of distortion prior to recording because some flavors of distortion that might seem acceptable (or even stylish) initially, may later prove to cause irreparable damage to parts of the sound (for example, "warm lows" but "harsh sibilance") or in louder or quieter sections of the recording. Experience shows that mic preamps and basic console routing paths should offer supreme fidelity otherwise the engineer has little control or choice of recorded "color" and little recourse to undo after the fact. Devices or circuits that can easily be bypassed are usually better choices when "color" is a consideration and this particularly is an area where one might consider comparing several such devices. Beware that usually deviations from linearity carry at least as much long-term penalty as initial appeal, and that one should always be listening critically when recording and generally "playing it safe" when introducing effects that cannot be removed.

1. Tsutomu Oohashi, Emi Nishina, Norie Kawai, Yoshitaka Fuwamoto, and Hishi Imai. *National Institute of Multimedia Education, Tokyo. "High Frequency Sound Above the Audible Range, Affects Brain Electric Activity and Sound Perception" Paper read at 91st. Convention of the A.E.S. October 1991. Section 7. (1), Conclusion.*
2. Miland Kunchur, Department of Physics and Astronomy, University of South Carolina. "Temporal resolution of hearing probed by bandwidth restriction", M. N. Kunchur, *Acta Acustica united with Acustica* 94, 594-603 (2008) (<http://www.physics.sc.edu/kunchur/Acoustics-papers.htm>)
3. Miland Kunchur, Department of Physics and Astronomy, University of South Carolina. *Probing the temporal resolution and bandwidth of human hearing*, M. N. Kunchur, *Proc. of Meetings on Acoustics (POMA) 2, 050006 (2008)*

5017 USAGE NOTES

The 5017's small size and feature set allows it to be used in many different ways, in both studio and live environments. The diagrams on the following pages show how to use the 5017 as a single channel or dual channel module. Here are some creative things to try:

For vocals, take two mics, your favorite condenser plugged into the Mic Input, and a SM57 or SM58 set up 6 inches closer to the vocalist and plugged into another mic pre, then into the 5017 Inst Input. Adjust Vari-Phase to taste, and maybe add some light compression from the 5017 followed by your usual vocal compressor, which may behave even nicer because of that touch of "pre-compression" from the 5017.

For synth(or another instrument), set the signal chain as seen for single channel use(Page 8), but place the mic a little further than normal from the amp, or pointed away from the amp to incorporate more room reflections. With the mic even further away, we might suggest using the Mic Pre Output sent to a separate track and the Blend control set to INST so you end up with separate "dry" and a "room" tracks(See Page 9 setup). In the latter example, the Phase Sweep may be rather subtle and the compressor can be set to operate on either the DI (dry) or mic (room) signal depending on the internal jumper. With the compressor set to the mic path, you may find this accentuates the room nicely, and if you are changing jumpers, you might want to audition the "slow" compressor jumper setting while you are there. This may work also work well for "re-amping" some tracks already recorded on the DAW, especially given the Phase Sweep and Compressor in the 5017.

Single Channel Use Blended DI and Mic Signals

When used for instruments, the 5017 can be used to phase align, combine and compress direct and miced instrument signals. To achieve this, use the DI for the instrument's direct signal and the mic preamp for the speaker cabinet signal. Connect the external amplifier to the passive DI thru on the 5017 faceplate. The blend control is used for mixing direct and amplified signals to achieve the desired tonality of the two sources, and the variphase is used to minimize or extenuate phase cancellations between the two signals. To compress the blended signal, the internal compressor jumper must be set to the blend path (this is the default setting). This technique could also be used to create a single, mixed output of a guitar and vocals.

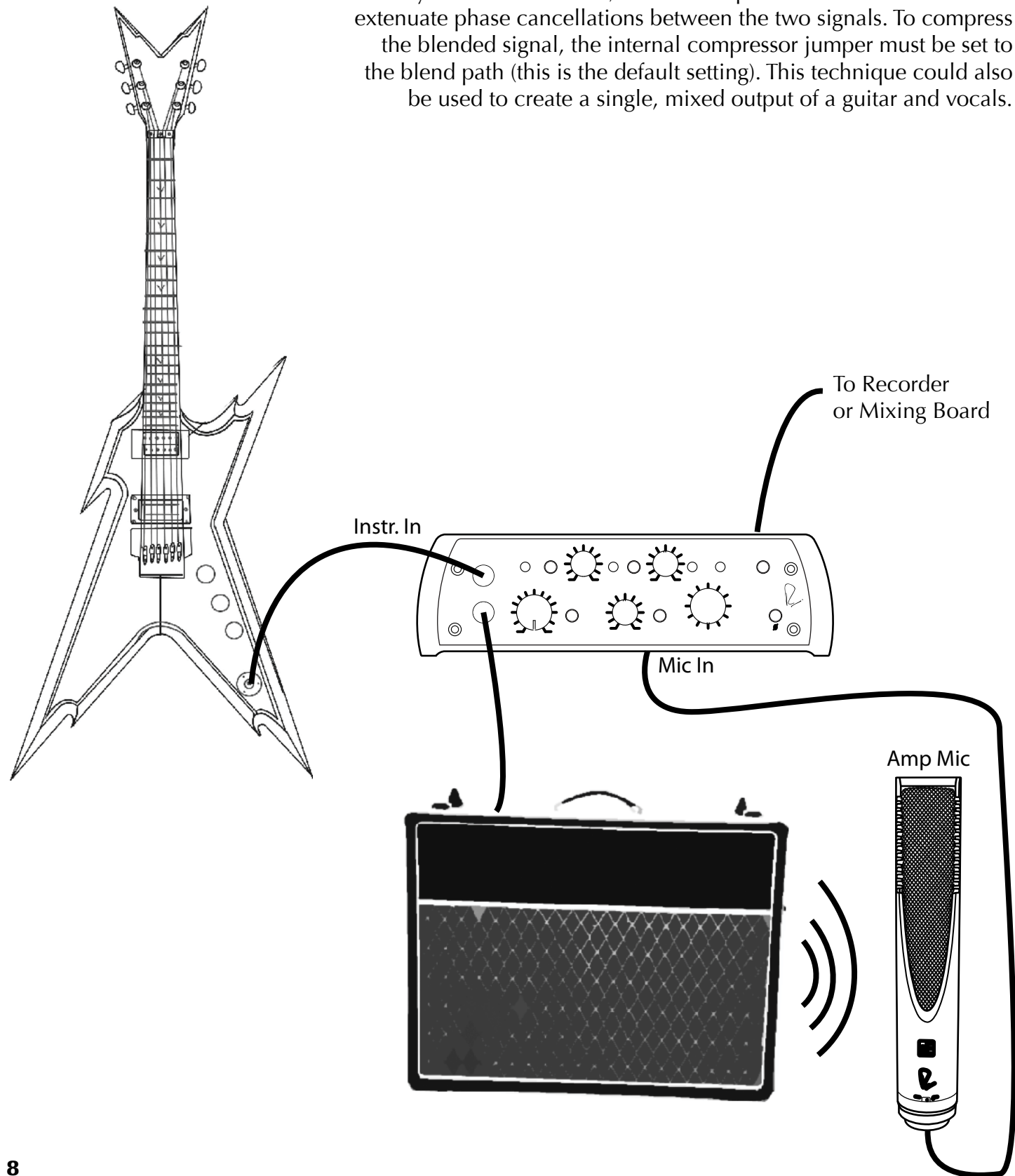

Dual Channel Use - Vocal and Instrument

Used as a two channel device, a lead singer / guitar player, can take the classic studio quality of the 5017 wherever they go. In this scenario, the vocal would use the mic input, the compressor and mic output, while the guitar would use the instrument input and blend output. To achieve this, the blend control should be selected as fully DI, and an internal jumper needs to be set to the mic path. When engaged, Silk mode would effect both vocal and guitar tracks, and the HPF control would affect only the mic path.

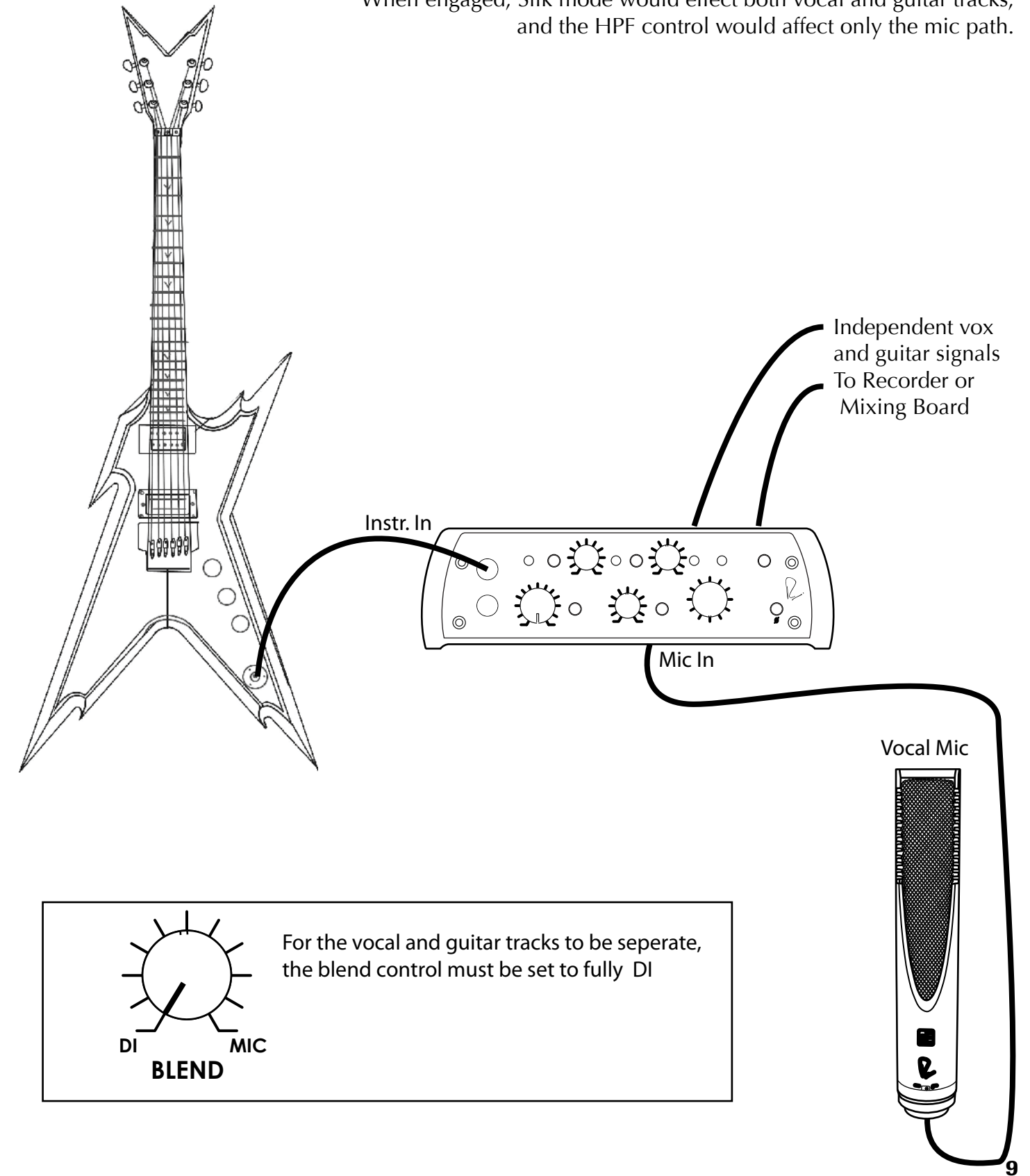

5017 FEATURES

MICROPHONE INPUT

The microphone input is balanced but not floating, being a variant of an instrumentation amplifier. Our well-proven “Transformer-Like-Amplifier” (T.L.A.) configuration is used, which includes an accurate toroidal Common Mode Low Pass Filter that rejects Common Mode signals and excludes frequencies above 150 kHz. (There are high powered broadcast transmitters at and above this frequency in several Continents and, even if you can’t hear them, any vestigial intermodulation products must be excluded!)

When the Mic Gain switch is set to Unity (0 dB), the Portico 5017 microphone pre-amplifier can handle a balanced input signal of more than +20 dBu without an input attenuator pad! This is a unique feature that enables this input to double as an additional line input.

THE MIC AND INSTRUMENT / BLEND OUTPUTS

The main output signal comes from the output transformer secondary which is balanced and ground free. A ground free connection guarantees freedom from hum and radio frequency interference when connected to a balanced destination such as the input to another Portico module or a high quality ADC. However the transformer may be used with one leg grounded without any change in performance. It is not necessary to “ground” one leg at the Portico output. It would normally get a ground connection when fed to equipment that is not balanced. Maximum output level is + 22 dBu, which provides a large margin over and above the likely maximum requirement of any destination equipment to which the 5017 is connected.

MIC GAIN

A 12-way precision rotary switch covering from Line (0) and Mic from 0 to 66 dB in 6 dB steps.

DI GAIN

Continuous gain control from 0dB to 30dB

IN and THRU 1/4” PHONE JACKS

These 2 jacks are used for DIRECT INJECTION (DI) or INSTRUMENT inputs and are simply paralleled and wired together. Inserting a plug into either jack breaks the normal MIC input and the user has the full range of MIC GAIN and TRIM. These jacks have a 3 mega ohm input impedance that will provide less loading (better highs) than most DI boxes, and the sheer amount of gain that is available makes these inputs extremely versatile.

THRESHOLD

When signals exceed the “threshold” level, the gain is reduced at a controlled 2:1 ratio, with attack and release time constants set to standard or fast depending on the internal jumper setting.

SILK

Much could be written about this feature, suffice to say, that it gives a subtle option to enhance sound quality in the direction of vintage modules. The silk button reduces negative feedback and adjusts the frequency spectrum to provide a very sweet and musical performance. We suggest you try it and make your own judgment.

BLEND

Combines the Mic and DI signals on the DI / Blend Output. When Blend is set to fully DI, the 5017 operates with two separate channels.

+48V

Back panel switch makes phantom power available at the microphone input.

PHASE

Push button inverts the polarity of the signal path. The symbol “Ø” is often used to denote opposite polarity.

HPF IN

The high pass filter is a valuable aid in any signal chain but particularly so in a microphone preamplifier. Signals below 80hz can be attenuated at a rate of 12db / octave, getting rid of building rumble, air handling motor hum etc.

INDICATORS

Indicators on the 5017 denote signal presence and clipping on both DI and mic signals, as well as compressor activation.

INTERNAL JUMPERS

Two internal jumpers in the 5017 can be set to change the compressor from the mic channel to the di / blend channel, and to change the compressor time constant from fast(default) to slow.

To change the compressor time constant to slow, move the J1 jumper(top of picture) away from the front faceplate.

To change the compressor position from di / blend to mic, us a pair of tweezers to move the jumper block on J2, J3 and J4 (behind the mic signal presence LED) to the right (when facing the faceplate).

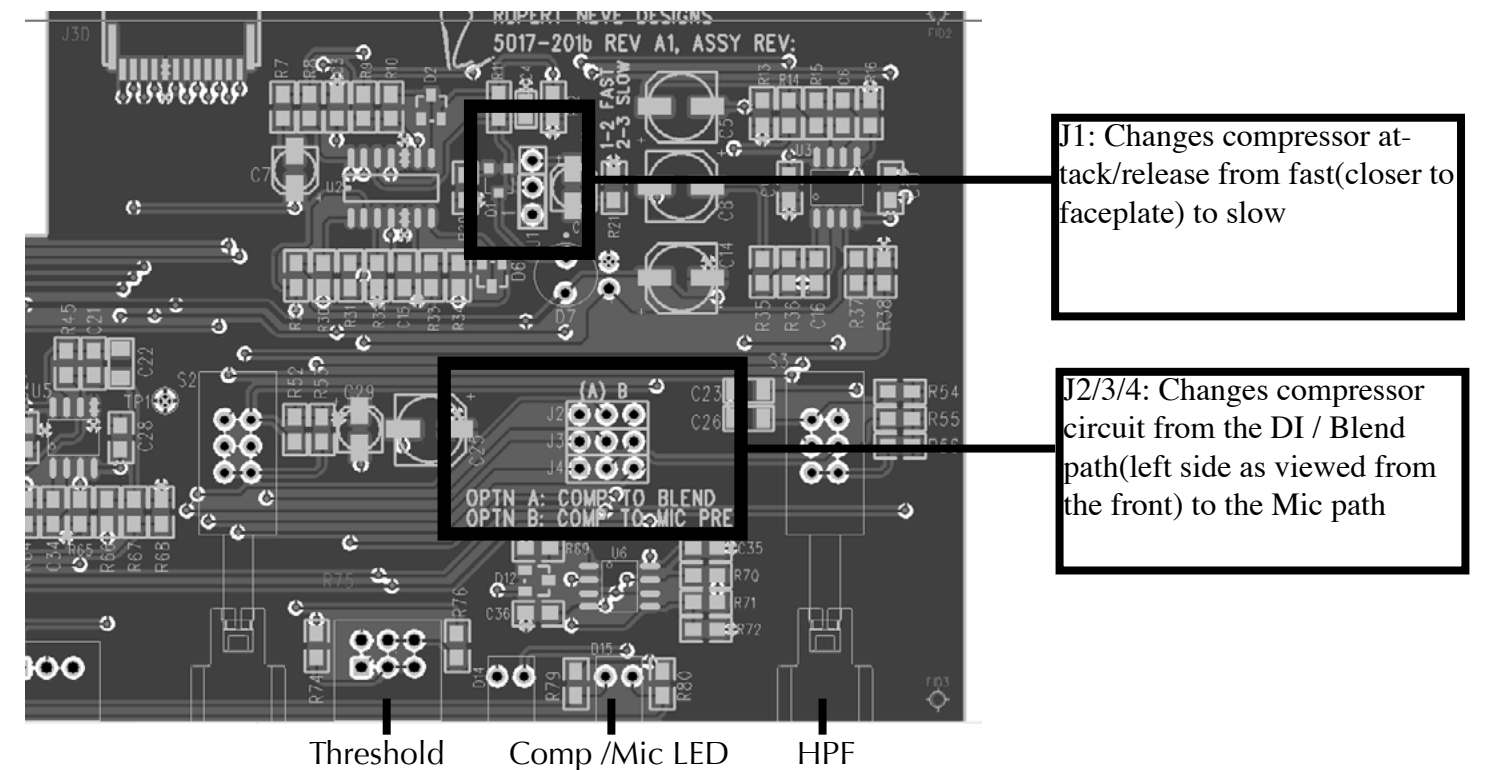

5017 RECALL SHEET

SPECIFICATIONS

Frequency Response:

Main Output, no load,
 -0.2 dB @ 10 Hz
 -3 dB @ 160 kHz

Noise:

Measured at Main Output, unweighted, 22Hz-22kHz,
 Terminated 150 Ohms.
 With gain at unity better than -100 dBu
 With gain at 66 dB better than -62 dBu
 Equivalent Input Noise better than -128 dBu
 Noise Factor 1.5dB

High Pass Filter:

Frequency: 80Hz
 Slope: 12 dB/Octave Bessel

Maximum Output Level:

Maximum output from 20 Hz to 40 kHz is +23 dBu.

Total Harmonic Distortion and Noise:

@ 1kHz, +20 dBu output: Main Output: Better than 0.001%
 @ 20Hz, +20 dBu output: Main Output: Better than 0.002%
 Silk Engaged: Better than 0.2% Second harmonic

Crosstalk:

Measured channel to channel: Better than -90 dB @ 15kHz.

Phantom Power:

+48 Volts DC +/- 1%

Power requirements:

12VDC is optimal voltage, but 9-15VDC is acceptable

Current consumption:

@ 9VDC Current is 1.3 A typical: Power = 11.7W
 @ 12VDC Current is 1.0 A typical: Power = 12.0 watts
 @ 15VDC Current is 800 mA typical: Power = 12.0 watts

Compressor

Threshold: Continuously Variable from -20dBu to +10dBu
 Ratio: Fixed at 2:1
 Attack & Release:
 Fast Mode Attack 40ms, Release 40ms
 Slow Mode Attack 100ms, Release 350ms

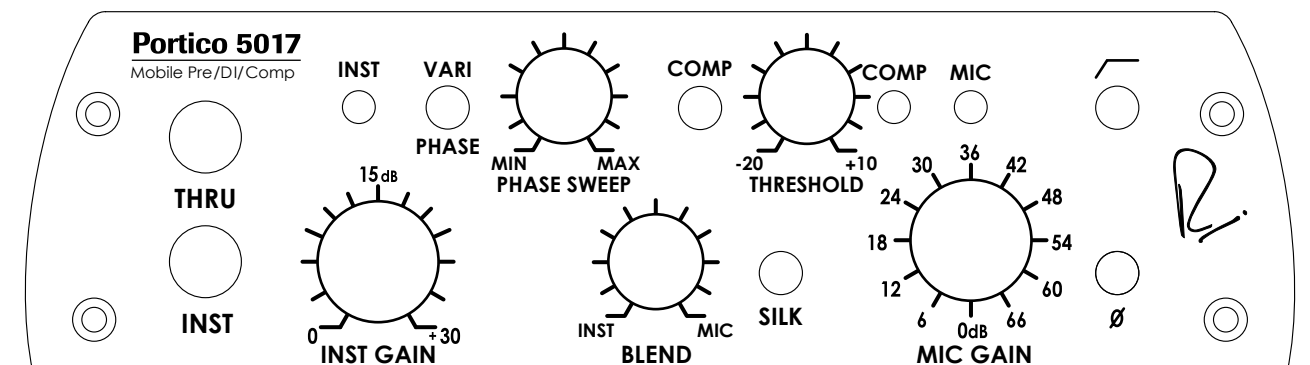
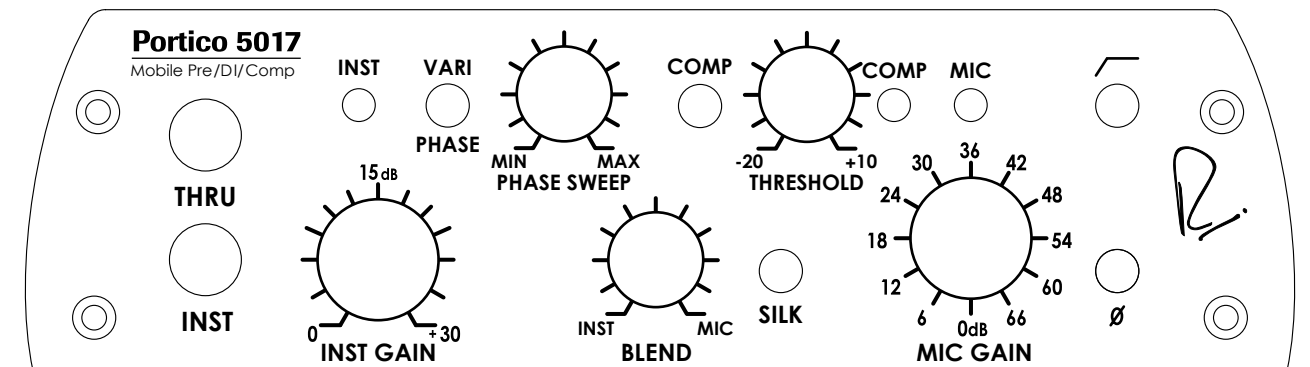
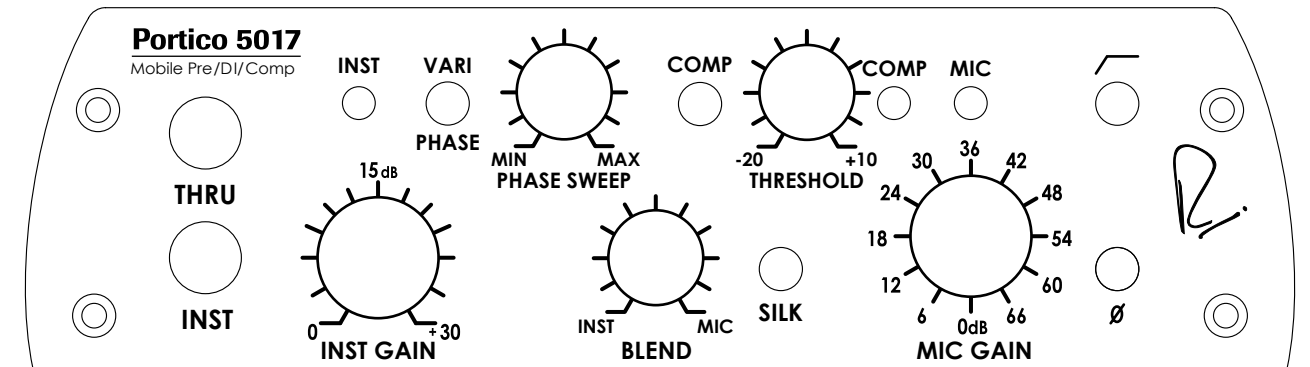
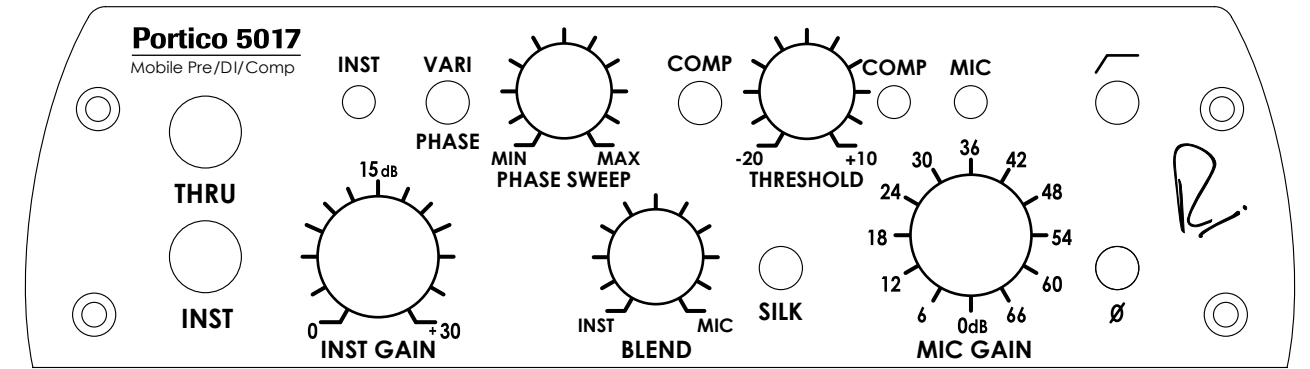

PRODUCT WARRANTY

Rupert Neve Designs warrants this product to be free from defects in materials and workmanship for a period of one (1) year from date of purchase, and agrees to remedy any defect identified within such one year period by, at our option, repairing or replacing the product.

LIMITATIONS AND EXCLUSIONS

This warranty, and any other express or implied warranty, does not apply to any product which has been improperly installed, subjected to usage for which the product was not designed, misused or abused, damaged during shipping, damaged by any dry cell battery, or which has been altered or modified in any way. This warranty is extended to the original end user purchaser only. A purchase receipt or other satisfactory proof of date of original purchase is required before any warranty service will be performed. THIS EXPRESS, LIMITED WARRANTY IS IN LIEU OF ALL OTHER WARRANTIES, EXPRESS OR IMPLIED, TO THE EXTENT ALLOWED UNDER APPLICABLE STATE LAW. IN NO EVENT SHALL RUPERT NEVE DESIGNS BE LIABLE FOR ANY SPECIAL, INCIDENTAL, OR CONSEQUENTIAL DAMAGES RESULTING FROM THE USE OF THIS PRODUCT. Some states do not allow the exclusion or limitation of consequential damages or limitations on how long an implied warranty lasts, so this exclusion may not apply to you.

WARRANTY SERVICE

If you suspect a defect in this product, please call us at 512-847-3013 or email us at support@rupertneve.com to discuss the suggested defect (it is possible that a suspected defect could be due to improper usage) and to obtain a return authorization number. It shall be your responsibility to pay for shipping the product to us, and, if the product is determined to be defective, our responsibility to pay for shipping the product back to you.



Rupert Neve Designs

PO Box 1969

Wimberley TX 78676

www.rupertneve.com

tel: +1 512-847-3013

fax: +1 512-847-8869